

Power Performance Improvement of 500W Vertical Axis Wind Turbine with Salient Design Parameters

Young-Tae Lee, Hee-Chang Lim

Abstract—This paper presents the performance characteristics of Darrieus-type vertical axis wind turbine (VAWT) with NACA airfoil blades. The performance of Darrieus-type VAWT can be characterized by torque and power. There are various parameters affecting the performance such as chord length, helical angle, pitch angle and rotor diameter. To estimate the optimum shape of Darrieus-type wind turbine in accordance with various design parameters, we examined aerodynamic characteristics and separated flow occurring in the vicinity of blade, interaction between flow and blade, and torque and power characteristics derived from it. For flow analysis, flow variations were investigated based on the unsteady RANS (Reynolds-averaged Navier-Stokes) equation. Sliding mesh algorithm was employed in order to consider rotational effect of blade. To obtain more realistic results we conducted experiment and numerical analysis at the same time for three-dimensional shape. In addition, several parameters (chord length, rotor diameter, pitch angle, and helical angle) were considered to find out optimum shape design and characteristics of interaction with ambient flow. Since the NACA airfoil used in this study showed significant changes in magnitude of lift and drag depending on an angle of attack, the rotor with low drag, long chord length and short diameter shows high power coefficient in low tip speed ratio (TSR) range. On the contrary, in high TSR range, drag becomes high. Hence, the short-chord and long-diameter rotor produces high power coefficient. When a pitch angle at which airfoil directs toward inside equals to -2° and helical angle equals to 0° , Darrieus-type VAWT generates maximum power.

Keywords—Darrieus wind turbine, VAWT, NACA airfoil, performance.

I. INTRODUCTION

DURING last a few decades, fuel prices have sky rocketed and global warming problem gets worse due to reckless use of fossil fuel. Consequently, as an alternative to fossil fuels, attention, and demand for new renewable energy has increased across the world. Among new renewable energy sources, wind power energy has been in the spotlight [1]. Wind turbines can be divided into two groups, namely horizontal axis wind turbine (HAWT) and vertical axis wind turbine (VAWT). In addition, there are two main types of VAWT, drag-type (Savonius) and lift-type (Darrieus) VAWT. Drag-type turbine has better initial start-up wind speed. On the other hand, drag-type shows low power generation efficiency compared to lift-type turbine. This paper works on Darrieus-type wind turbine which has better efficiency than Savonius VAWT in a condition of wind speed exceeding a specific level. Among the existing studies on Darrieus-type VAWT, there was a review work by Gorelov [2]. In the study, Gorelov

examined the performance characteristics of Darrieus VAWT in accordance with various design parameters (for example, the number of blades, cord length, thickness, pitch angle and rotor diameter, etc.) by extensively combining precedent experimental studies published earlier than 2009. Parashchikov [3] and Fujisawa [4] carried out the study on stall and pitch control for Darrieus-type blade. Owing to evolution of computer technology, three-dimensional CFD (Computational Fluid Dynamics) have led to high accuracy model and calculation. Using the technologies, a wide variety studies on blade shape development are being actively conducted. As to numerical studies focusing on small-scale VAWT, Ferreira [5], employing air as fluid, presented a detailed state of art of different strategies for predicting aerodynamic characteristics of a vertical axis wind turbine. Maitre [6] applied sliding mesh strategy to a two blade VAWT using Fluent® software combined with the one equation turbulence model Spalart-Allmaras. Howell [7] worked on Darrieus VAWT with specific shape. He investigated torque, power coefficient and flow characteristics by comparing the results of wind tunnel test and three-dimensional numerical analysis. According to the study, the numerical analysis results are significantly close to experimental results. However, the results from the previous studies were obtained mainly using specific shape and only a part of interested parameters. Numerical approaches also have been done within limitation like a part of turbulence models. So the results tend to be inconsistent. This paper conducted design optimization study on Darrieus blade considering various parameters such as chord length, rotor diameter, pitch angle and helical angle using ANSYS FLUENT®, three-dimensional CFD commercial program. According to the previous studies done so far, it is clear that the studies on performance estimation for small Darrieus-type VAWT of 500W are extremely insufficient and the comparisons result with experimental data are not enough. In this paper, wind tunnel test was also carried out installing Darrieus VAWT with NACA airfoil blades. The experimental results obtained by this wind tunnel experiment were verified in conjunction with numerical results. This paper aims to propose optimum shape of Darrieus VAWT showing the maximum power at different design variables. This study aims to analyse flow characteristics caused by interaction between blade and flow in accordance with respective design parameters and temporal flow and pressure characteristics for wind load. This study also aims to investigate fluid dynamic characteristics appearing at the shape with maximum power.

Young-Tae, Lee and Hee-Chang, Lim are with the School of Mechanical Engineering, Pusan National University, Jangjeon-dong, Geumjeoun-gu, Busan 609-735, South Korea (e-mail: hclim@pusan.ac.kr).

II. NUMERICAL ANALYSIS AND EXPERIMENT METHOD IN WIND TUNNEL

A. Darrieus Numerical Model

The Darrieus blade profiles considered in this paper are NACA0015. The shape characteristics of VAWT used in wind tunnel experiment are as follows: its airfoil is NACA0015, chord length is 150mm, rotor diameter (D) is 800mm, length (L) is 600mm and aspect ratio (L/D) is 0.75. The turbine consists of three blades with identical airfoil shape. The three blades are connecting to a center shaft. Schematic diagram about Darrieus VAWT used in this paper is shown in Fig. 1. There are several design parameters for Darrieus VAWT, which are a pitch angle (ϕ), aspect ratio (L/D), solidity (NC/D) and helical angle. According to the design parameters, this study takes into consideration several different cases as follows: cases with varying solidity, the six different cases at varying blade pitch angle of -6° , -3° , -2° , -1° , -0° and 3° , and four different cases at varying helical angle in range of 0° , -30° with an interval of 10° .

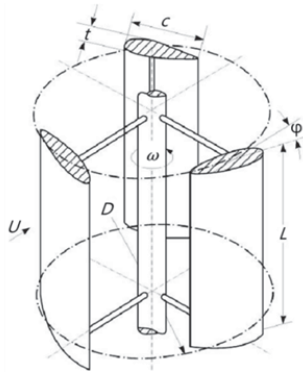

Fig. 1 Schematic diagram of Darrieus type vertical axis wind turbine

B. Computational Grids

The computational mesh is consisted of tetrahedron shape in most areas, but it is consisted of hexahedron shape close to the blade surface for more accurate result. For the proper simulation of wind turbine, several separate zones are considered and a rotating region of wind turbine mainly moves relatively to the other zones (stationary regions). Fig. 2 indicates the computational grid with rotational region and stationary region. The number of grid for the calculation was 1,500,000 for rotational region and 500,000 for stationary region and about 2,000,000 for total domain. The full size of computational domain is same with real wind tunnel size located in PNU (i.e. $2\text{m}^{\text{width}} \times 2\text{m}^{\text{height}}$) for comparing with wind tunnel test.

C. Governing Equation and Turbulence Model

The governing equation used in this study is the Navier-Stokes equation and the discretization method is the finite volume method. In unsteady RANS modeling, the flow properties are disintegrated into their mean and fluctuating components by Reynolds decomposition and substituted into the Navier-Stokes equations, which yields the time-averaged RANS equations for incompressible Newtonian fluids as:

$$\frac{\partial \bar{u}_i}{\partial x_i} = 0 \quad (1)$$

$$\frac{\partial \bar{u}_i}{\partial t} + \bar{u}_j \frac{\partial \bar{u}_i}{\partial x_j} = -\frac{1}{\rho} \frac{\partial \bar{p}}{\partial x_i} + \nu \frac{\partial^2 \bar{u}_i}{\partial x_j^2} - \overline{u_j' \frac{\partial u_i'}{\partial x_j}} + f_i \quad (2)$$

where \bar{u}_i and u_i' are the mean and fluctuating parts of the velocity component u_i in the x_i -direction, respectively, p is the mean pressure, ρ is the density, and ν is the viscosity. Appearance of the fluctuations associated with turbulence give rise to additional stresses in the fluid, the so-called Reynolds stresses, $\overline{\rho u_i' u_j'}$ which need to be modelled in order to mathematically close the problem. The term f_i represents 'other' body forces (forces per unit volume), such as gravity or centrifugal force, and these forces are ignored for simplicity.

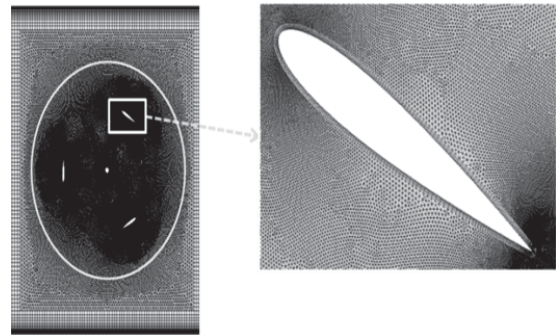

Fig. 2 Blade shape and analysis domain grid for flow analysis of Darrieus-type VAWT

The choice of the turbulence models is important in order to get a good numerical result and to satisfy the time required to achieve solution. The RNG $k-\epsilon$ turbulence model is known to predict flow fields involving large flow separations more accurately. So RNG $k-\epsilon$ turbulence model was used for the present simulation.

D. Boundary Conditions for Numerical Analysis

Boundary conditions for numerical analysis were set as described in Fig. 3 with the aim to accurately investigate torque and power characteristics of Darrieus-type VAWT. The inlet condition is a constant velocity. The outlet condition is an outflow condition without gradient towards outlet except for pressure gradient. In addition, wall condition is given to side, top, and bottom surface. The size of forward direction of the rotor is 5D, the size of left and right direction is identical to wind tunnel size ($2\text{m} \times 2\text{m}$), and the size of backward direction is 7D. To explore performance characteristics at various tip speed ratio (TSR), we adjust TSR through rotational speed of rotor. TSR is a blade tip speed against wind speed, which is defined as (3). Power performance of the rotor can be presented as power coefficient depending on TSR.

$$\text{TSR} = \frac{\text{Tip Speed}}{\text{Wind Velocity}} = \frac{\omega \times R}{U_\infty} \quad (3)$$

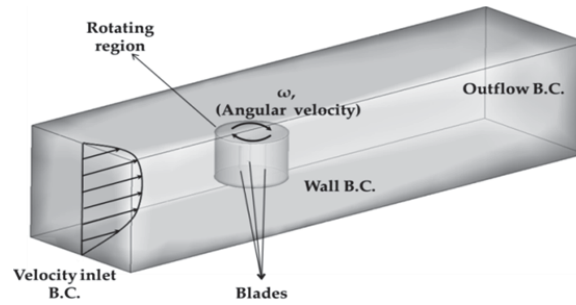

Fig. 3 Rotational direction, approach flow and ambient boundary condition of Darrieus-type VAWT used in numerical analysis

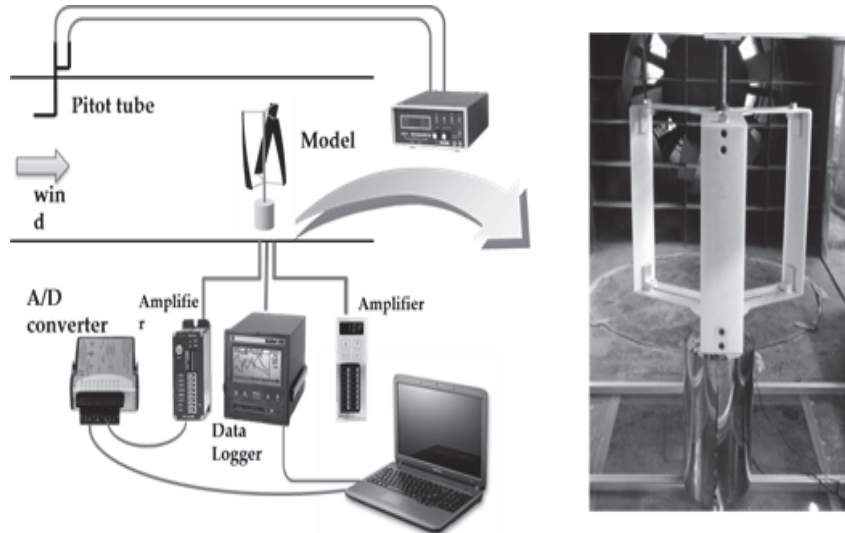

Fig. 4 Measurement System and Darrieus-type VAWT experiment model used for wind tunnel experiment

E. Wind Tunnel Experiment

In this paper, we conducted experiment using the open large-scale boundary layer wind tunnel at Pusan National University as shown in Fig. 4. The dimension of the wind tunnel is 2.0m × 2.1m × 20m (width × height × length). Maximum speed is 23m/s. For results analysis, torque coefficient (C_Q) and power coefficient (C_P) are used. Torque coefficient and power coefficient were calculated by (4) and (5) respectively. Where Q is a torque [$N \cdot m$], ρ denotes the air density [kg/m^3] and A is a cross-sectional area of the rotor [m^2].

$$C_Q = \frac{Q}{0.5\rho ARV_\infty^2} \quad (4)$$

$$C_P = \frac{Q\omega}{0.5\rho AV_\infty^3} \quad (5)$$

III. RESULT AND DISCUSSION

A. Comparison of Numerical and Experimental Results

Numerical results were obtained by simulating the exactly same conditions as wind tunnel in three-dimensional numerical analysis areas. Fig. 5 shows the numerical and experimental results for comparison. In Fig. 5, horizontal axis represents TSR, while vertical axis represents power coefficient produced by Darrieus VAWT. As generally

revealed, performance curve of Darrieus-type VAWT appears to be parabola and reaches maximum value at TSR of 0.8 - 2.0. From the results obtained in this study, maximum power occurs at TSR of 1.2-1.4. At this point, power coefficient appears to be about 0.23. Particularly, interesting result was observed in wind tunnel experiment at higher and lower of TSR = 1.2. Power coefficient decreases showing parabola shape in an area with higher TSR than 1.2, whereas power coefficient shows drastic decrease in an area with lower TSR than 1.2. These numerical analysis results are significantly consistent with experimental results even though a bit of discrepancy exists. It implies that optimized design can be achieved using only numerical results when modifying design parameter values of Darrieus VAWT. To save the numerical analysis cost, all other parameters except for helical angle were examined by 2D analysis method. Based on the analysis results, flow characteristics and tendencies for each parameter were investigated. Furthermore, design optimization was carried out, which are discussed in next section.

B. Performance Evaluation with Varying Chord Lengths

To investigate chord length's variation affecting solidity which is one of design parameters of Darrieus-type VAWT, we obtained torque and power coefficient against TSR with fixed rotor diameter as shown in Fig. 6. Solidity is the ratio of length of blades to the rotor diameter(R), defined by (6).

$$\sigma(\text{solidity}) = \frac{\text{The number of blades} \times \text{chord length}}{\text{Diameter of rotor}} = \frac{N \times C}{D} \quad (6)$$

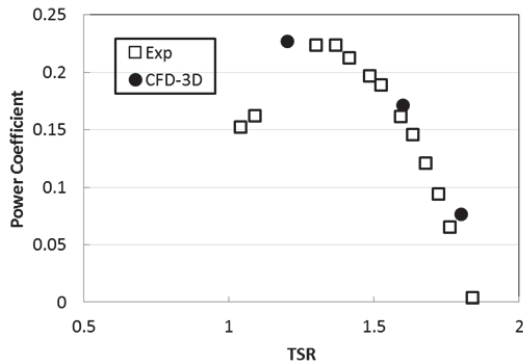

Fig. 5 Comparison of three-dimensional numerical analysis results and wind tunnel experiment results

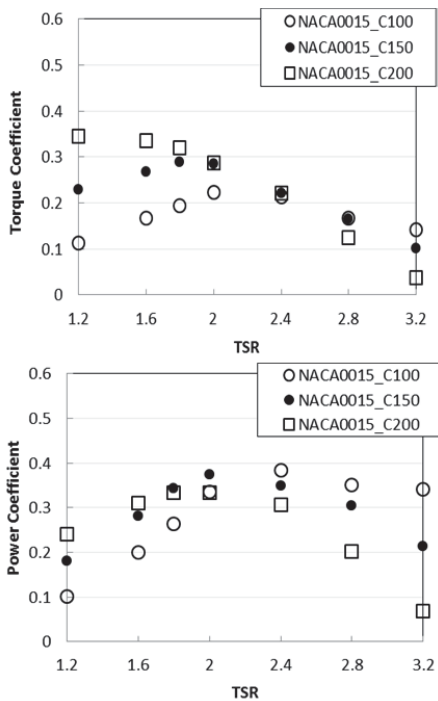

Fig. 6 Torque and power coefficient variations according to changing chord lengths

Fig. 6 compares three different chord lengths, 100mm, 150mm and 200mm. The solidity for each chord length appears to be 0.38, 0.56 and 0.75 respectively. According to the Fig. 6, when TRS is 2 or less, the rotor with chord length of 200mm (with highest solidity) shows highest torque and power coefficient. On the other hand, when TSR is 2.4 or higher, the rotor with chord length of 100mm (with lowest solidity) shows highest torque and power coefficient. These observations indicate that dominant power affecting blades is lift due to low rotational speed at low TSR. However, as TSR increases, rotational speed of the blades increases. Consequently, among powers affecting the blades, influences of drag become dominant. In case that lift is dominant power,

the long-chord length rotor shows high power coefficient. On the contrary, when drag affects as dominant power, the long-chord length rotor shows low power coefficient since it gets stronger resistance.

C. Performance Evaluation with Varying Pitch Angle

To explore the influences of pitch angle on the blade, we considered six distinct cases with different pitch angles such as -6° , -3° , -2° , -1° , 0° and 3° . Pitch angle, as shown in Fig. 7, has positive value when it directs towards inside, while it has negative value when it directs towards outside. The results presented in Fig. 8, are power coefficients at TSR of 1.6 with varying pitch angles. Fig. 8 indicates that the highest power coefficient occurs at pitch angle of -2° . In other ranges except for this angle, power coefficient decreases showing parabola curve pattern.

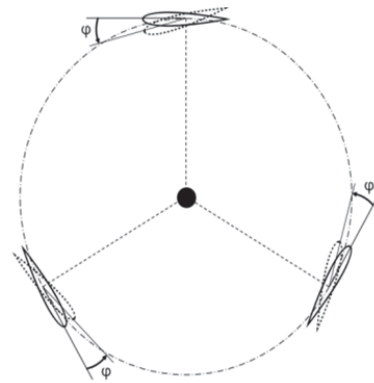

Fig. 7 Definition of pitch angle of the blade used in numerical analysis

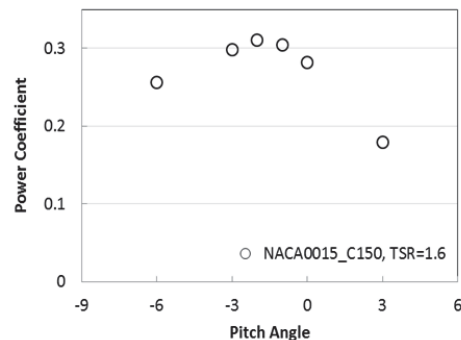

Fig. 8 Variations of power coefficients at varying pitch angles

D. Performance Evaluation with Varying Helical Angle

Among performance characteristics of Darrieus-type VAWT, helical angle is not possible to analyse in 2D simulation. Therefore, the performance characteristics against helical angle can be analysed only in 3D simulation. Darrieus VAWT profile used for analysis purpose is NACA0018. In terms of NACA0018, its length, rotor diameter and chord length is 1,600mm, 1,800mm and 200mm respectively. Helical angle applied to blade for three-dimensional analysis, is set to 0° (A0), 10° (A10), 20° (A20) and 30° (A30), as shown in Fig. 9. Fig. 10 shows a graph presenting power

estimation results for Darrieus-type VAWT at varying helical angle against distinct TSR occurring at each rotor. The TSR range shown in horizontal axis is from 0.8 to 2.4 with an interval of 0.2. According to the results obtained in this study, the highest power occurs when TSR equals to 2.0, which reaches up to 0.32. At this moment, output power generated is up to around 980W. With numerical analysis, the output power seems significantly high. However, it is predicted that actual wind rotor might generate lower power than this numerical result due to mechanical and electrical loss. It is also observed that helical angle has no significant influence on power performance. In low TSR range, furthermore, performance decreases, as helical angle increases.

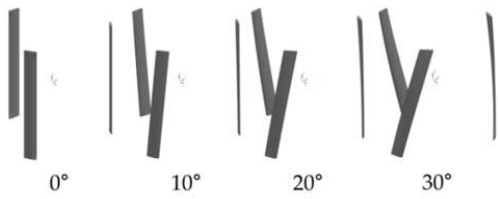

Fig. 9 Three-dimensional Darrieus Blade with varying helical angle

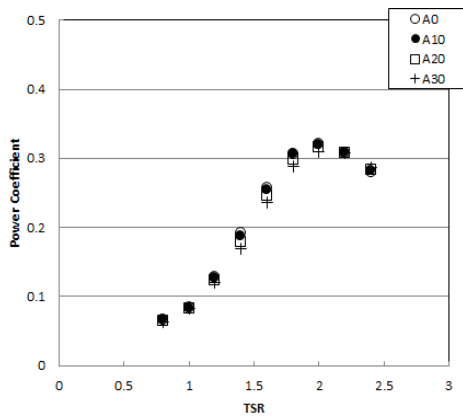

Fig. 10 Variations of power coefficients at varying helical angle

IV. CONCLUSION

In this study, wind tunnel experiment and numerical analysis were conducted on Darrieus-type VAWT with NACA airfoil blade. This study aims to propose an optimum shape which produces maximum output power in Darrieus-type VAWT by varying values of design parameters. Additionally, variations of flow characteristics and performance characteristics appearing while design parameters are being varied were derived numerically. The results can be summarized as follows.

- (1) As solidity increases, power coefficient becomes high in a low TSR range. However, in high TSR range, as rotational speed increases, drag force also increases. Therefore the model with high solidity produces low power coefficient because it is affected by stronger drag force.
- (2) In terms of power performance at varying pitch angles, highest efficiency occurs at TSR of 1.6 and pitch angle of

-2° . When TSR changes, however, optimum pitch angle is predicted to change in accordance with the change of angle of attack of the blade.

- (3) Regarding power performance at varying helical angle of the blade, highest performance appears at shape without helical angle. If performance is the only factor to be taken into account, it is considered to be reasonable that helical angle excludes in consideration because twisted blade shows low power coefficient even though it is hard to produce.

ACKNOWLEDGEMENTS

This work was supported by the Human Resources Development of the Korea Institute of Energy Technology Evaluation and Planning (KETEP) grant funded by the Korea government Ministry of Knowledge Economy (No. 20134030200290). In addition, this research was supported by Basic Science Research Program through the National Research Foundation of Korea (NRF) funded by the Ministry of Education, Science and Technology (2013005347).

REFERENCES

- [1] IEA report (2012). World Energy Outlook 2012 – Renewable Energy Outlook (Chapter 7). International Energy Agency.
- [2] Gorelov, D. N. (2010). Energy characteristics of Darrieus rotor (review). *Thermophysics and Aeromechanics*, 17-3, p301-308.
- [3] Paraschivoiu, I., Trifu, O., Saeed, F. (2009). H-Darrieus Wind Turbine with Blade Pitch Control. *International Journal of Rotating Machinery*, 2009-505343, p1-7.
- [4] Fujisawa, N., Shibuya, S. (2001). Observations of dynamic stall on Darrieus wind turbine blades. *Journal of Wind Engineering and Industrial Aerodynamics*, 89-2, p201-214.
- [5] Ferreira, C.J.S. (2009). The near wake of the VAWT. 2D and 3D views of the VAWT aerodynamics, Ph.D. Thesis, Delft University of Technology.
- [6] Maitre, T., Achard, J.L., Guitet, L., and Ploesteanu, C. (2005). Marine turbine development: numerical and experimental investigations. *Sci. Bull. Timisoara Politechnic Univ.*, 50, p59-66.
- [7] Howell, R., Qin, N., Edwards, J., Durrani, N. (2010). Wind tunnel and numerical study of a small vertical axis wind turbine. *Renewable Energy*, 35, p412-422.