

Power Quality Improvement Using UPQC Integrated with Distributed Generation Network

B. Gopal, Pannala Krishna Murthy, G. N. Sreenivas

Abstract—The increasing demand of electric power is giving an emphasis on the need for the maximum utilization of renewable energy sources. On the other hand maintaining power quality to satisfaction of utility is an essential requirement. In this paper the design aspects of a Unified Power Quality Conditioner integrated with photovoltaic system in a distributed generation is presented. The proposed system consist of series inverter, shunt inverter are connected back to back on the dc side and share a common dc-link capacitor with Distributed Generation through a boost converter. The primary task of UPQC is to minimize grid voltage and load current disturbances along with reactive and harmonic power compensation. In addition to primary tasks of UPQC, other functionalities such as compensation of voltage interruption and active power transfer to the load and grid in both islanding and interconnected mode have been addressed. The simulation model is design in MATLAB/ Simulation environment and the results are in good agreement with the published work.

Keywords—Distributed Generation(DG), Interconnected mode, Islanding mode, Maximum power point tracking (MPPT), Power Quality (PQ), Unified power quality conditioner (UPQC), Photovoltaic array (PV).

I. INTRODUCTION

ELECTRIC utilities and end users of electric power are becoming increasingly concerned about meeting the growing energy demand. Seventy five percent of total global energy demand is supplied by the burning of fossil fuels. But increasing air pollution, global warming concerns, diminishing fossil fuels and their increasing cost have made it necessary to look towards renewable sources as a future energy solution. Since the past decade, there has been an enormous interest in many countries on renewable energy for power generation. The market liberalization and government's incentives have further accelerated the renewable energy sector growth [1], [2].

Renewable energy source (RES) integrated at distribution level is termed as distributed generation. The utility is concerned due to the high penetration level of intermittent RES in distribution systems as it may pose a threat to network in terms of stability, voltage regulation and power-quality issues. Therefore, the DG systems are required to comply with

strict technical and regulatory frameworks to ensure safe, reliable and efficient operation of overall network. With the advancement in power electronics and digital control technology, the DG systems can now be actively controlled to enhance the system operation with improved PQ at PCC. However, the extensive use of power electronics based equipment and non-linear loads at PCC generate harmonic currents, which may deteriorate the quality of power [3], [4].

With increasing applications of nonlinear and electronically switched devices in distribution systems and industries, power quality problems, such as harmonics, flicker, and imbalance have become serious concerns. In addition, lightning strikes on transmission lines, switching of capacitor banks, and various network faults can also cause PQ problems, such as transients, voltage sag/swell, and interruption. On the other hand, an increase of sensitive loads involving digital electronics and complex process controllers requires a pure sinusoidal supply voltage for proper load operation [5].

In order to meet PQ standard limits, it may be necessary to include some sort of compensation. Modern solutions can be found in the form of active rectification or active filtering [6]. A shunt active power filter is suitable for the suppression of negative load influence on the supply network, but if there are supply voltage imperfections, a series active power filter may be needed to provide full compensation [7].

Implementation of Custom Power Devices (CPD) like UPQC in DG or micro grid systems to improve the power quality is gaining greater importance [8]-[11]. UPQC is the integration of series and shunt active filters, connected back-to-back on the dc side, sharing a common DC capacitor [12] as shown in Fig. 1. The series component of the UPQC is responsible for mitigation of the supply side disturbances: voltage sags/swells, flicker, voltage unbalance and harmonics. It inserts voltages so as to maintain the load voltages at a desired level; balanced and distortion free. The shunt component is responsible for mitigating the current quality problems caused by the consumer: poor power factor, load harmonic currents, load unbalance etc. It injects currents in the ac system such that the source currents become balanced sinusoids and in phase with the source voltages.

In recent years, the concept of distributed generation, which permits installation of relatively small scale power generators at the medium/low voltage distribution levels of the power system, has gained widespread attention due to its technical, economical, and environmental benefits [13]. Among DG systems, photovoltaic solar systems have attracted considerable investment in several countries [14], such that significant penetration of the PV energy into distribution

B. Gopal is with the Dept. of Electrical and Electronics Engineering, Khammam Institute of Technology & Sciences, Khammam, A.P, India (e-mail: bgopal49@yahoo.com).

Pannala Krishna Murthy is with the Dept. of Electrical and Electronics Engineering, Swarna Bharathi Institute of Science & Technology Khammam, A.P, India (e-mail: krishnamurthy.pannala@gmail.com).

G.N. Sreenivas is with the Dept. of Electrical and Electronics Engineering, JNTU College of Engineering, Hyderabad, A.P, India (e-mail: gnsngns.srinivas785@gmail.com).

networks has already taken place in Europe, through single- and three-phase systems, and more penetration is anticipated worldwide. So far, PV systems of single or double digit megawatt (MW) capacities have been connected to the power system, mainly, at the sub transmission voltage levels. At the distribution voltage levels, most PV systems mainly consist of rooftop installations with capacities of a few kilowatts which are unlikely to make an impression on the distribution networks and the loads. These PV systems are not even permitted to cause a reverse power flow. This is, however, not the case for large scale PV systems which have considerably higher capacities and more sophisticated controls. Thus, in view of the increasing market for multi megawatt photovoltaic systems and in response to utility companies concerns about the impact of large-scale PV systems on the feeders/ customers, investigations on the control, dynamic properties, transient performance, and interactions with the network/loads of large-scale distributed PV systems seem to be timely and of importance [15]-[18].

In this paper, the proposed configuration is new connection of a Unified Power Quality Conditioner in a distributed generation integrated photovoltaic system is presented. The proposed system consist of series inverter, shunt inverter are connected back to back on the dc side and share a common dc-link capacitor with Distributed Generation through a boost converter. Therefore power can transfer from grid to load, to compensate the voltage sag and swell, voltage interruption, harmonics and reactive power in both islanding and interconnected modes.

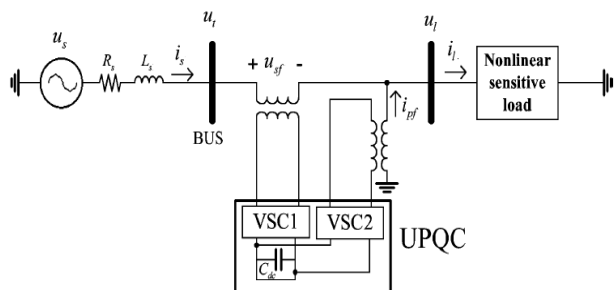

Fig. 1 Basic configuration of the UPQC

II. PROPOSED UPQC-DG SYSTEM

A. Circuit Configuration

The single line diagram of Distributed Generation with UPQC as shown in Fig. 2. The UPQC-DG is connected to feeder BUS and with voltage of u_{t1} . The shunt part of the UPQC-DG is connected to load with a current of i_{l1} . Supply voltage is denoted by u_{s1} while load voltage is u_{l1} . Finally, feeder current is denoted by i_{s1} and load current is i_{l1} .

Bus voltage u_{t1} is distorted and may be subjected to sag/swell. The load is a nonlinear/sensitive load which needs a pure sinusoidal voltage for proper operation while its current is non-sinusoidal and contains harmonics. If the load is a sensitive/critical load which needs a purely sinusoidal voltage and must be fully protected against distortion, sag/swell, and

interruption. These types of loads primarily include production industries and critical service providers, such as medical centers, airports, or broadcasting centers where voltage interruption can result in severe economic losses or human damages.

B. UPQC-PV Structure

The internal structure of a UPQC-PV is shown in Fig. 3. It consists of two voltage source converters which are connected back to back through a common dc-link capacitor. In the proposed configuration, voltage source converter1 is connected in series with BUS and voltage source converter2 is connected in parallel with load at the end of Feeder.

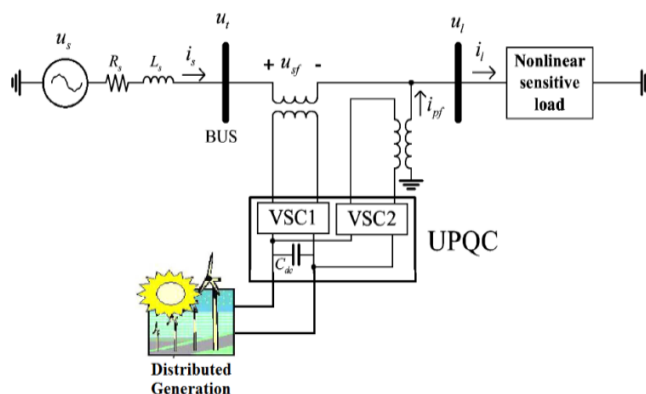

Fig. 2 UPQC with DG connected to the DC link

where PV source is connected to a DC link in the UPQC as an energy source. In this case, UPQC finds the ability of injecting power using PV to sensitive load during source voltage interruption. Common grid connected PV system structure is shown in Fig. 4 which is composed of PV array, DC/DC and DC/AC converters. In this proposed system, two operational modes are studied as follow:

- 1) Interconnected mode; where PV transfers power to load and source.
- 2) Islanding mode; where the source voltage is interrupted and PV provides a part of load power separately.

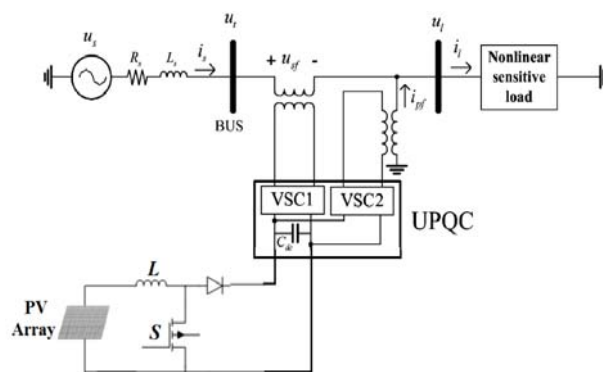

Fig. 3 Configuration of proposed UPQC with PV

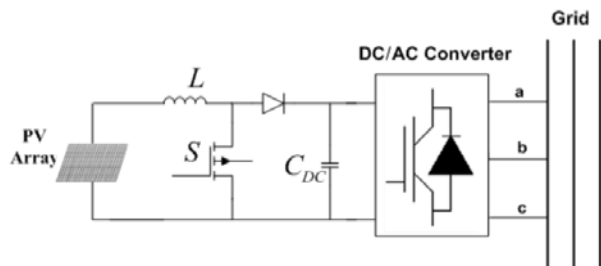

Fig. 4 General structure of grid connected PV systems

Each of the three VSCs in Fig. 3 is realized by a three-phase converter with a commutation reactor and high-pass output filter as shown in Fig. 5. The commutation reactor (L_f) and high-pass output filter (R_f, C_f) are connected to prevent the flow of switching harmonics into the power supply.

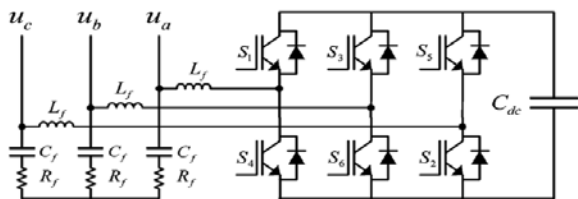

Fig. 5 Schematic structure of a VSC

The aims of the UPQC-PV shown in Fig. 3 are:

- 1) To regulate the load voltage against (u_{ll}) sag/swell and disturbances in the system to protect the nonlinear/sensitive load.
- 2) To compensate for the reactive and harmonic components of nonlinear load current (i_{ll}).
- 3) To compensate voltage interruption and active power transfer to the load and grid in islanding mode to protect sensitive critical load.

II. CONTROLLER DESIGNING

The controlling structure of proposed system is composed of three following parts:

- A. Shunt VSC2
- B. Series VSC1
- C. DC/DC converter

Controlling strategy is designed and applied for two interconnected and islanding modes. In interconnected mode, source and PV provide the load power together while in islanding mode; PV transfers the power to the load lonely. By removing voltage interruption, system returns to interconnected mode.

A. Shunt VSC

Functions of the shunt-VSC are:

1. To compensate for the reactive component and the harmonic component of load current.
2. To compensate for interruptions and is inject the active power generated by PV system to the load.

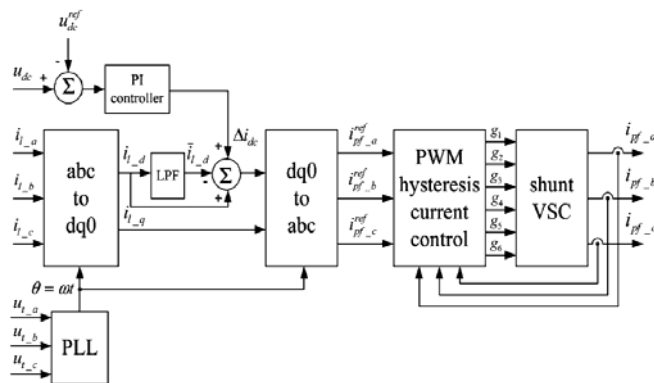

Fig. 6 Control block diagram of the shunt VSC

1. Shunt VSC in Interconnected Mode

Fig. 6 shows the control block diagram for the shunt voltage source converter. The measured load current ($i_{l,abc}$) is transformed into the synchronous dqo reference frame by using,

$$I_{L-dqo} = T_{abc}^{dqo} i_{l-abc} \quad (1)$$

where the transformation matrix T_{abc}^{dqo} is

$$T_{abc}^{dqo} = \frac{2}{3} \begin{bmatrix} \cos(\omega t) & \cos(\omega t - 120^\circ) & \cos(\omega t + 120^\circ) \\ -\sin(\omega t) & -\sin(\omega t - 120^\circ) & -\sin(\omega t + 120^\circ) \\ \frac{1}{2} & \frac{1}{2} & \frac{1}{2} \end{bmatrix} \quad (2)$$

By this transform, the fundamental positive-sequence component, which is transformed into dc quantities in the d and q axes, can be easily extracted by low-pass filters (LPFs). Also, all harmonic components are transformed into ac quantities with a fundamental frequency shift

$$i_{L-d} = \bar{i}_{L-d} + \tilde{i}_{L-d} \quad (3)$$

$$i_{L-q} = \bar{i}_{L-q} + \tilde{i}_{L-q} \quad (4)$$

where i_{L-d} and i_{L-q} are d-q components of load current, \bar{i}_{L-d} and \bar{i}_{L-q} are dc components, and \tilde{i}_{L-d} and \tilde{i}_{L-q} are the ac components of i_{L-d} and i_{L-q} [6]-[8].

If i_s is the feeder current and i_{pf} is the shunt voltage source converter current and knowing $i_s = i_l + i_{pf}$, then d-q components of the shunt voltage source converter reference current are defined as follows:

$$i_{pf-d}^{ref} = i_{L-d} \quad (5)$$

$$i_{pf-q}^{ref} = i_{L-q} \quad (6)$$

Consequently, the d-q components of the feeder current are

$$i_{s-d} = i_{L-d} \quad (7)$$

$$i_{s-q} = 0 \quad (8)$$

This means that there are no harmonic and reactive components in the feeder current. Switching losses cause the dc-link capacitor voltage to decrease. Other disturbances, such as the sudden variation of load, can also affect the dc link. In order to regulate the dc-link capacitor voltage, a proportional–integral (PI) controller is used as shown in Fig. 6. The input of the PI controller is the error between the actual capacitor voltage (u_{dc}) and its reference value (u_{dc}^{ref}). The output of the PI controller (i.e. Δi_{dc}) is added to the component of the shunt-ML voltage source converter reference current to form a new reference current as follows:

$$\begin{aligned} i_{pf-d}^{ref} &= i_{L-d} + \Delta i_{dc} \\ i_{pf-q}^{ref} &= i_{L-q} \end{aligned} \quad (9)$$

As shown in Fig. 6, the reference current in (9) is then transformed back into the abc reference frame. By using PWM hysteresis current control, the output compensating currents in each phase are obtained [19]-[22]. The UPQC-PV System operation with interconnected mode is shown in Fig. 7.

$$i_{pf-abc}^{ref} = T_{dco}^{abc} i_{pf-dqo}^{ref} \quad (T_{dco}^{ref} = T_{abc}^{dqo1}) \quad (10)$$

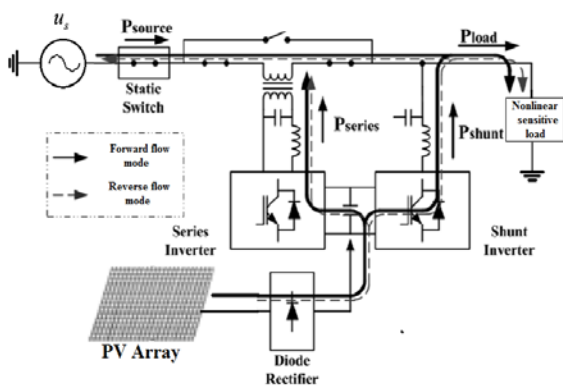

Fig. 7 UPQC-PV System operation with interconnected mode

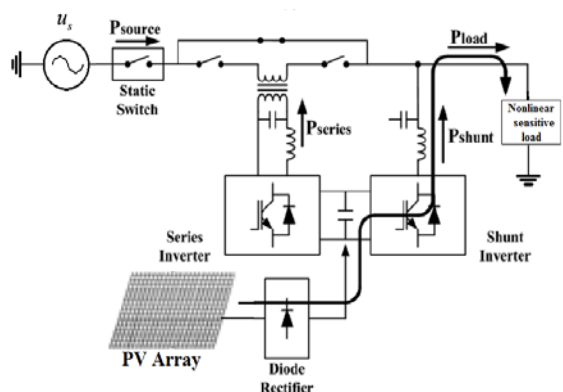

Fig. 8 UPQC-PV System operation with islanding mode

2. Shunt VSC in Islanding Mode

If voltage interruption occurs, the shunt inverter's operation will switch from interconnected mode to islanding mode. PV

system provides required active power to stabilize load voltage. In this case, shunt inverter controls output voltage and current in order to inject to load using PI controller. Fig. 6 shows the block diagram of shunt inverter control based on the above relations to control the shunt inverter during voltage interruption and islanding mode [23]-[25]. The UPQC-PV System operation with Islanding mode is shown in Fig. 8.

B. Series VSC

Functions of the series voltage source converter are:

- 1) To mitigate voltage sag and swell.
- 2) To compensate for voltage distortions, such as Harmonics.

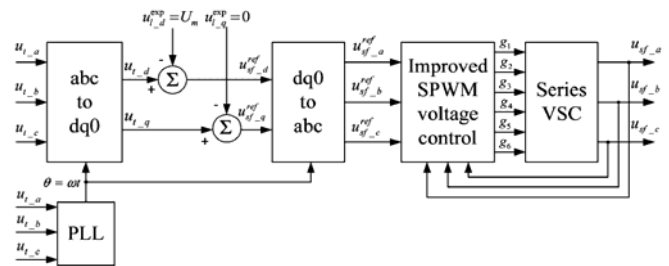

Fig. 9 Control block diagram of the series VSC

The control block diagram of series voltage source converter is shown in Fig. 9. The bus voltage ($u_{t,dqo}$) is detected and then transformed into the synchronous dqo reference frame using

$$u_{t,dqo} = T_{dco}^{abc} u_{t,abc} = u_{t1p} + u_{t1n} + u_{t10} + u_{th} \quad (11)$$

where

$$\begin{aligned} u_{t1p} &= [u_{t1p-d} \ u_{t1p-q} \ 0]^T \\ u_{t1n} &= [u_{t1n-d} \ u_{t1n-q} \ 0]^T \\ u_{t10} &= [0 \ 0 \ u_{00}]^T \\ u_{th} &= [u_{th-d} \ u_{th-q} \ u_{th-0}]^T \end{aligned} \quad (12)$$

u_{t1p} , u_{t1n} and u_{t10} are fundamental frequency positive, negative, and zero sequence components, respectively, and u_{th} is the harmonic component of the bus voltage. According to control objectives of the UPQC, the load voltage should be kept sinusoidal with constant amplitude even if the bus voltage is disturbed. Therefore, the expected load voltage in the synchronous dqo reference frame ($u_{l,dqo}^{exp}$) only has one value.

$$u_{l,dqo}^{exp} = T_{dco}^{abc} u_{l,abc}^{exp} = \begin{bmatrix} U_m \\ 0 \\ 0 \end{bmatrix} \quad (13)$$

where the load voltage in the abc reference frame ($u_{l,abc}^{exp}$) is

$$u_{l,abc}^{exp} = \begin{bmatrix} U_m \cos(\omega t) \\ U_m \cos(\omega t - 120) \\ U_m \cos(\omega t + 120) \end{bmatrix} \quad (14)$$

The compensating reference voltage in the synchronous dqo reference frame (u_{l-dqo}^{ref}) is defined as:

$$u_{l-dqo}^{ref} = u_{t-dqo} - u_{l-dqo}^{exp} \quad (15)$$

This means $u_{t1p,d}$ in (12) should be maintained at U_m while all other unwanted components must be eliminated. The compensating reference voltage in (15) is then transformed back into the abc reference frame. By using an improved SPWM voltage control technique (sine PWM control with minor loop feedback) [26], the output compensation voltage of the series VSC can be obtained.

C. DC/DC Converter Controlling to Obtain the Maximum Power of PV Array

PV systems are nonlinear power sources whose output power is greatly under effect of two radiation and environment temperature elements. One of the disadvantages of these systems is their low efficiency, because solar cells rarely operate at their maximum power point. So in order to increase the efficiency, as much power as possible should be extracted from the array. Temperature variation effects on cell voltage and radiation variation effects on cell current. Fig. 10 shows the equivalent circuit of PV array used in simulation [27]-[29].

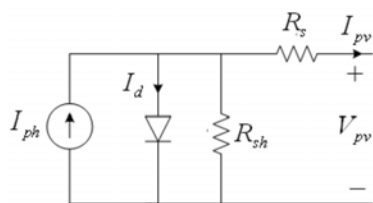

Fig. 10 Equivalent circuit of PV array

In connection of the PV array to grid, a DC/DC converter is applied and is used to adapt the variable voltage of PV with the voltage of grid and extract the maximum power from the array. In respect to Fig. 11 MPPT is obtained by controlling

the duty cycle of DC/DC converter switch. The widely used MPPT algorithms can be broadly classified as:

- 1) Perturbation and Observation (P&O) Method
 - a. Conventional P&O Method
 - b. Incremental Conductance Method
- 2) Linearity-based Methods:
 - a. Short-circuit current method
 - b. Open Circuit Voltage Method
- 3) Switching Frequency Modulation Method
- 4) Ripple Correlation Control Method

In this paper, algorithm of perturbation and observation (P&O) method is one of the most common methods used to achieve the maximum power point. In P&O method, a short perturbation is created in array's output voltage and then output voltage is measured. If this perturbation causes an increase in output power, then the next perturbation will be applied in this direction, and if it causes reduction, then voltage perturbation will be applied in reverse direction and this process continues till achieving the maximum power point of the array [30]. The advantage of this method is simple operation. the duty cycle of converter switch is determined by measuring voltage and array's current values in specific periods of time and applying maximum power tracking algorithm. The PV Array Current-voltage Curves & Power-voltage Curves are shown in Fig. 12.

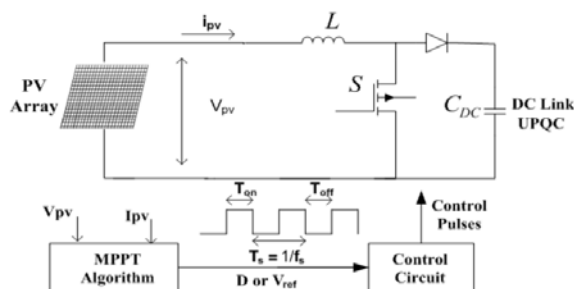

Fig. 11 Schematic block diagram of MPPT of PV array

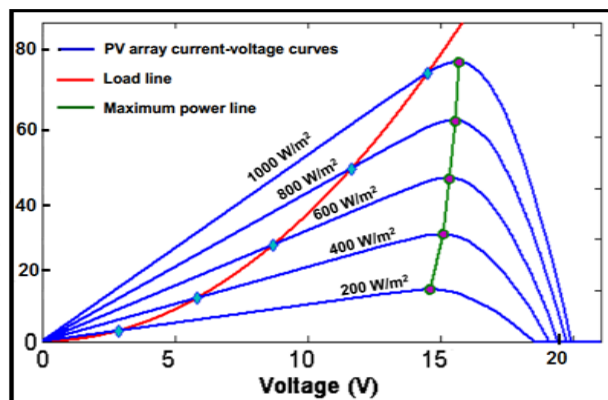
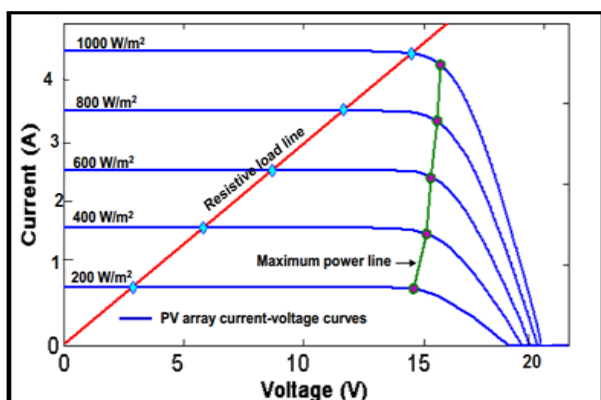

Fig. 12 PV Array Current-voltage Curves & Power-voltage Curves

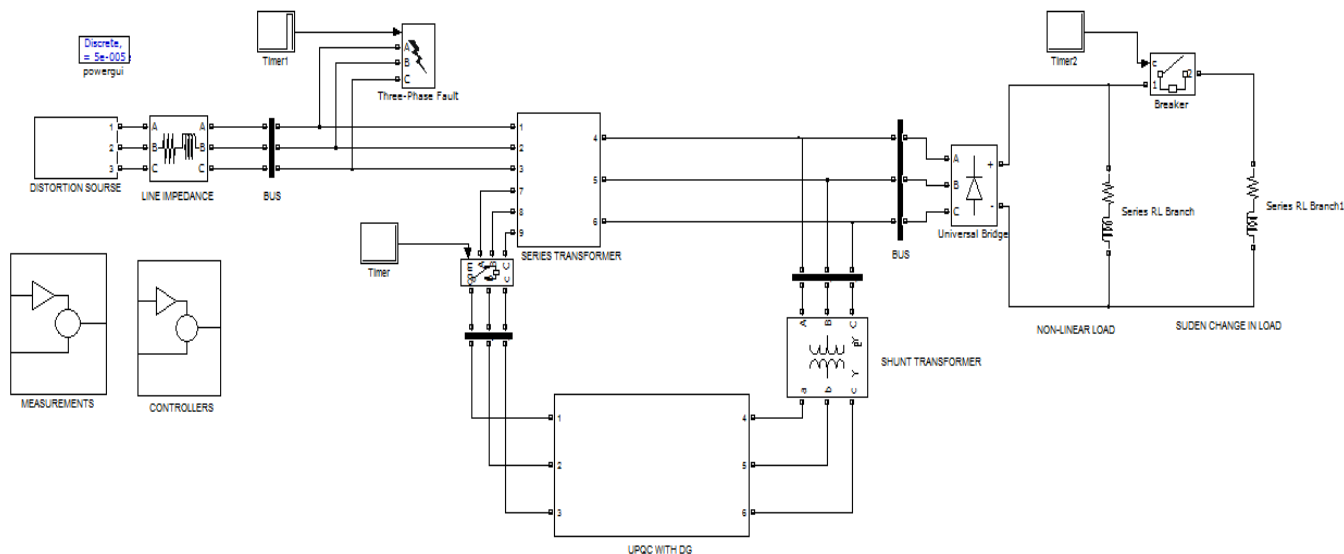

Fig. 13 Simulink model of UPQC with PV system

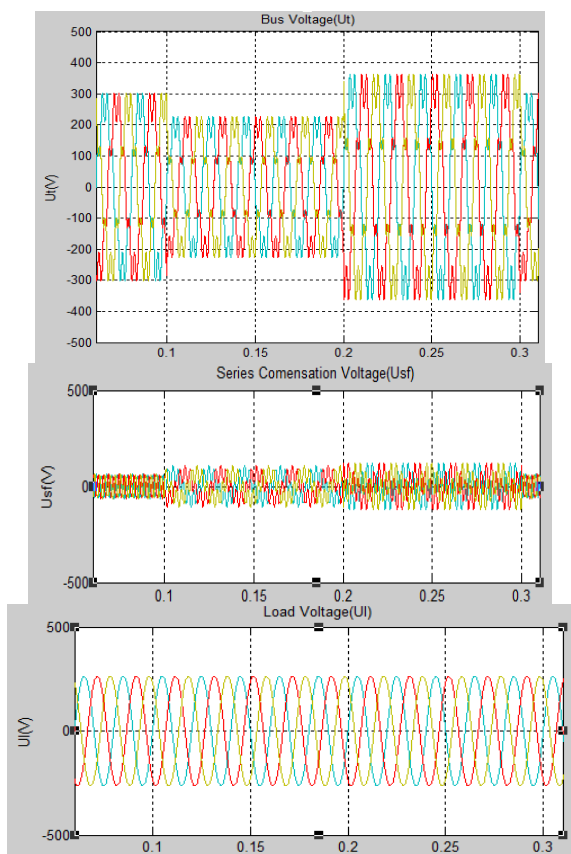

Fig. 14 Bus voltage, series compensating voltage, and load voltage

III. SIMULATION RESULTS

The proposed UPQC-PV and its control schemes have been tested through extensive case study simulations using MATLAB. In this section, simulation results are presented, and the performance of the proposed UPQC-PV system is shown.

A. Distortion and Sag/Swell on the Bus Voltage

Let us consider that the simulink model of power system in Fig. 13 consists of three-phase three-wire 380(v) (rms, L-L), 50-Hz utilities. The BUS1 voltage contains the seventh-order harmonic with a value of 22%, voltage contains 25% sag between $0.1s < t < 0.2s$ and 20% swell between $0.2s < t < 0.3s$.

The UPQC-PV is switched on at 0.02 s. The BUS voltage, the corresponding compensation voltage injected by VSC1, and finally load L voltage are shown in Fig. 8. As shown in the Fig. 8, distorted voltage of BUS is satisfactorily compensated for across the loads L with very good dynamic response. The nonlinear load current, its corresponding compensation current injected by VSC2, compensated Feeder1 current, and, finally, the dc-link capacitor voltage are shown in Fig. 14. The distorted nonlinear load current is compensated very well, and the total harmonic distortion (THD) of the feeder current is reduced from 28.5% to less than 5%. Also, the dc voltage regulation loop has functioned properly under all disturbances, such as sag/swell in both feeders.

B. Upstream Fault on Feeder

When a fault occurs in Feeder (in any form of L-G, L-L-G, and L-L-L-G faults), the voltage across the nonlinear sensitive/ critical load L is involved in sag/swell or interruption. This voltage imperfection can be compensated for by PV source through VSC2.

In this case, the power required by load L is supplied through PV system and VSC2. This implies that the power semiconductor switches of VS12 and VSC2 must be rated such that total power transfer is possible. This may increase the cost of the device, but the benefit that may be obtained can offset the expense. In the proposed configuration, the nonlinear sensitive/critical load on Feeder is fully protected against distortion, sag/swell, and interruption. Furthermore, the regulated voltage across the sensitive load on Feeder1 can supply several customers who are also protected against distortion, sag/swell, and momentary interruption. Therefore,

the cost of the UPQC-PV must be balanced against the cost of interruption, based on reliability indices, such as the customer average interruption duration index (CAIDI) and customer average interruption frequency index (CAIFI). It is expected that the UPQC-PV cost can be recovered in a few years by charging higher tariffs for the protected lines.

The performance of the UPQC-PV under a fault condition on Feeder is tested by applying a three-phase fault to ground on Feeder between $0.6s < t < 0.7s$. Simulation results are shown in Fig. 15.

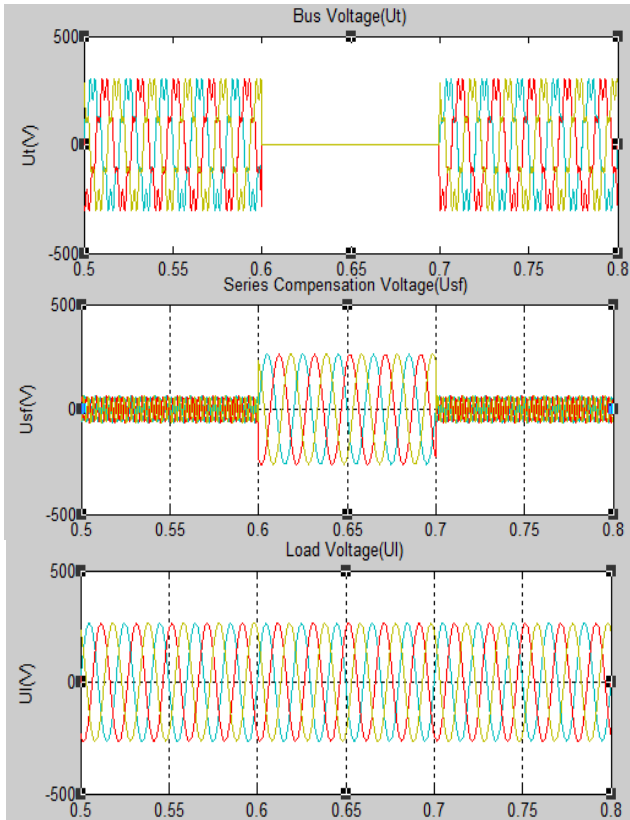

Fig. 15 Simulation result for upstream fault on feeder: Bus voltage, compensating voltage, load voltage

C. Load Change

To evaluate the system behavior during a load change, the nonlinear load L is doubled by reducing its resistance to half at $t = 0.5s$. The system response is shown in Fig. 16. It can be seen that as load L changes and the load voltage is remain undisturbed, the dc bus voltage is regulated, and the nonlinear load current is compensated.

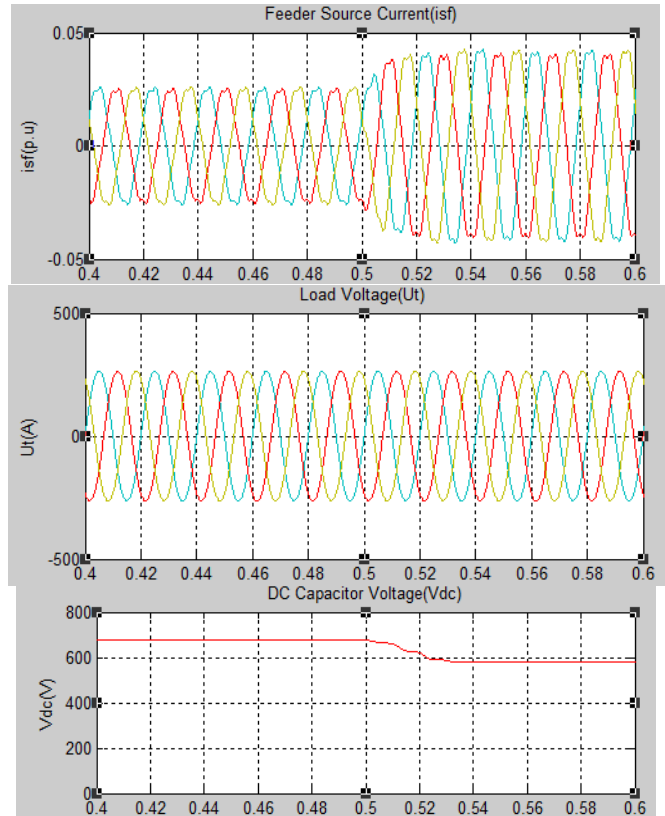
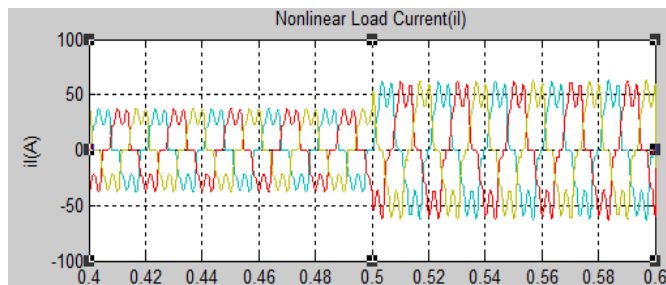

Fig. 16 Simulation results for load change: nonlinear load current, Feeder current, load voltage, and dc-link capacitor voltage

IV. CONCLUSION

The new configuration is named unified power-quality conditioner with Photo Voltaic System (UPQC-PV). Compared to a conventional UPQC, the proposed topology is capable of fully protecting critical and sensitive loads against distortions, sags/swell, and interruption in both islanding and interconnected modes. The performance of the UPQC-PV is evaluated under various disturbance conditions and it offers the following advantages:

- 1) To regulate the load voltage against sag/swell and disturbances in the system to protect the nonlinear/sensitive load.
- 2) To compensate for the reactive and harmonic components of nonlinear load current.
- 3) To compensate voltage interruption and active power transfer to the load and grid in islanding mode to protect sensitive critical load.
- 4) Depending upon the ratings, the combined system can reduce the cost up to one fifth of the separate system.

Capacity enhancement has been achieved using multi-level or multi-module and central control mode, however, the flexibility of UPQC to increase its capacity in future and to cope up with the increase load demand in medium voltage distribution system.

APPENDIX

TABLE I
UPQC-PV SYSTEM PARAMETERS

System Quantities	Values
System fundamental frequency(f)	50Hz
Voltage source(Us1)	380V(L-L rms) phase angle of 0°
Feeder Impedance (Rs+j2πfLs)	1+j0.314Ω
Load (L) Non-Linear/Sensitive Load	A three-phase diode rectifier that supplies a load of R=10 Ω,L=30μH
Series VSC-1 single phase Transformers	5KVA,linear type,10% Leakage reactance
Shunt VSC-2 single phase Transformers	10KVA,linear type,10% Leakage reactance
Filter Capacitor(Cf)	100μF
Filter Resistor (Rf)	0.1 Ω
Commutation Reactor(Ld)	50mH
DC Capacitor(Cdc)	2000 μF
PV Array Rating	40kW
Vdcref	600V

ACKNOWLEDGMENT

The author B. Gopal expresses sincere thanks to the Management, the Principal and the Staff members of the Department of EEE of Khammam Institute of Technology & Sciences, Khammam for the continued support in executing this work.

REFERENCES

[1] J. M. Carrasco, L. G. Franquelo, J. T. Bialasiewicz, E. Galván, R. C.P. Guisado, M. Á. M. Prats, J. I. León, and N. M. Alfonso, "Power electronic systems for the grid integration of renewable energy sources: A survey," *IEEE Trans. Ind. Electron.*, vol. 53, no. 4, pp. 1002–1016, Aug. 2006.

[2] J. H. R. Enslin and P. J. M. Heskes, "Harmonic interaction between a large number of distributed power inverters and the distribution network," *IEEE Trans. Power Electron.*, vol. 19, no. 6, pp. 1586–1593, 2004.

[3] D. D. Sabin and A. Sundaram, "Quality enhances reliability," *IEEE Spectr.*, vol. 33, no. 2, pp. 34–41, Feb. 1996.

[4] M. Rastogi, R. Naik, and N. Mohan, "A comparative evaluation of harmonic reduction techniques in three-phase utility interface of power electronic loads," *IEEE Trans. Ind. Appl.*, vol. 30, no. 5, pp. 1149–1155, Sep./Oct. 1994.

[5] A. Ghosh and G. Ledwich, "A unified power quality conditioner (UPQC) for simultaneous voltage and current compensation," *Elect Power Syst. Res.*, pp. 55–63, 2001.

[6] B. Gopal, P. Krishna Murthy and G.N.Sreenivas, "Power Quality Improvement using 24 pulse Bridge Rectifier for an Isolated Power Generation" International Journal of Advanced and Innovative Research (IJAIR), Volume 1, Issue 3, August 2012, pp.32-38.

[7] F. Blaabjerg, R. Teodorescu, M. Liserre, and A. V. Timbus, "Overview of control and grid synchronization for distributed power generation systems," *IEEE Trans. Ind. Electron.*, vol. 53, no. 5, pp. 1398–1409, Oct. 2006.

[8] B. Renders, K. De Gussemme, W.R. Ryckaert, K. Stockman, L. Vandevelde, and M. H. J. Bollen, "Distributed generation for mitigating voltage dips in low-voltage distribution grids," *IEEE Trans. Power Del.*, vol. 23, no. 3, pp. 1581–1588, Jul. 2008

[9] B Han, B Bae, H Kim, S Baek, "Combined Operation of Unified Power Quality Conditioner with Distributed Generation", IEEE Trans Power Delivery, vol. 21(1), 2006, pp. 330 – 338.

[10] J. P. Pinto, R. Pregitzer, L. F. C. Monteiro, and J. L. Afonso, "3-phase 4-wire shunt active power filter with renewable energy interface," presented at the Conf. IEEE Renewable Energy & Power Quality, Seville, Spain, 2007.

[11] A Ghosh and G Ledwich, "Power quality enhancement using custom power devices", Kluwer Academic, 2002.

[12] P. Jintakosonwit, H. Fujita, H. Akagi, and S. Ogasawara, "Implementation and performance of cooperative control of shunt active

filters for harmonic damping throughout a power distribution system," *IEEE Trans. Ind. Appl.*, vol. 39, no. 2, pp. 556–564, Mar./Apr. 2003.

[13] B. Gopal, P. Krishna Murthy and G.N.Sreenivas, "A Review on UPQC for Power Quality Improvement in Distribution System" Global Journal of Researches in Engineering (GJRE-F), Volume 13, Issue 7, Version 1.0, July- 2013, pp.49-57.

[14] V. Khadkikar, A. Chandra, A. O. Barry, and T. D. Nguyen, "Application of UPQC to protect a sensitive load on a polluted distribution network," in *Proc. Annu. Conf. IEEE Power Eng. Soc. Gen. Meeting* 2006, pp. 867–872.

[15] A Kumar, "A Ghosh, Interline Unified Power Quality Conditioner", IEEE Trans Power Delivery, Vol. 22(1), 2007, pp. 364-372.

[16] B. Gopal, K.K. Vasishtha Kumar and Ch. Ramulu, "Performance of MC-UPQC in unbalanced source voltage and voltage sag/swell migration conditions" *ACEEE Trans. in International Journal on Recent Trends in Engineering & Technology (IJRET)*, Vol. 05, No. 02, Mar, 2011, pp.157-159.

[17] V. Khadkikar, A. Chandra, A. Barry, and T. Nguyen, "Conceptual Study of unified power quality conditioner (UPQC)," in *Proc. IEEE Int Symp Ind. Electron.*, Jul. 9–13, 2006, pp. 1088–1093

[18] M. Singh and A. Chandra, "Power maximization and voltage sag/swell ride-through capability of PMSG based variable speed wind energy conversion system," in *Proc. IEEE 34th Annu. Conf. Indus. Electron. Soc.*, 2008, pp. 2206–2211.

[19] P. Rodriguez, J. Pou, J. Bergas, J. I. Candela, R. P. Burgos, and D. Boroyevich, "Decoupled double synchronous reference frame PLL for power converters control," *IEEE Trans. Power Electron.*, vol. 22, no. 2, pp. 584–592, Mar. 2007.

[20] P. Krishna Murthy, J. Amarnath, S. Kamakshaiiah and B.P. Singh "Wavelet Transform approach for Detection and Location of Faults in HVDC System," *IEEE Region 10 colloquium and the third ICIS, Kharagpur, India, Dec. 8-10, 2008*, pp.1-6.

[21] R. Mastromauro, M. Liserre, and A. Dell' Aquila, "Single-phase Grid connected photovoltaic systems with power quality conditioner functionality," in *Proc. Power Electron. Appl.*, Sep. 2–5, 2007 pp.1-11.

[22] M. Oprisan and S. Pneumaticos, "Potential for electricity generation from emerging renewable sources in Canada," in *Proc. IEEE EIC Climate Change Technology Conf.*, May 2006, pp. 1–9.

[23] M. Aredes, K. Heumann, and E. H. Watanabe, "An universal active power line conditioner," *IEEE Trans. Power Del.*, vol. 13, no. 2, pp. 545–551, Apr. 1998.

[24] M. Hu and H. Chen, "Modeling and controlling of unified power quality compensator," in *Proc. 5th Int. Conf. Advances in Power System Control, Operation and Management*, Hong Kong, China, 2000, pp. 431–435.

[25] G. L. Campen, "An analysis of the harmonics and power factor effects at a utility intertie photovoltaic system," *IEEE Trans. Power App. Syst.*, vol. PAS 101, no. 12, pp. 4632–4639, Dec. 1982.

[26] N. Srisaen and A. Sangswang, "Effect of pv grid-connected system location on a distribution system," in *Proc. IEEE Asia Pacific Conf. Circuit and Systems*, Dec. 2006, pp. 852–855.

[27] L. Wang and Y. Lin, "Dynamic stability analysis of photovoltaic array connected to a large utility grid," in *Proc. IEEE Power Eng. Soc. Winter Meeting*, Jan. 2000, vol. 1, pp. 476–480.

[28] A. Woyte, R. Belmans, and J. Nijs, "Testing and islanding protection function of photovoltaic inverters," *IEEE Trans. Energy Convers.*, vol. 18, no. 1, pp. 157–162, Mar. 2003.

[29] S. Zheng, P. Wang, and L. Ge, "Study on pwm control strategy of photovoltaic grid-connected generation system," in *Proc. IEEE Int. Conf. Power Electronics and Motion Control*, Shanghai, China, Aug. 2006, vol. 3.

[30] T. Esham and P. L. Chapman, "Comparison of photovoltaic array maximum power point tracking techniques," *IEEE Trans. Energy Convers.*, vol. 22, no. 2, pp. 434–449, Jun. 2007.



B. Gopal received B.Tech and M.Tech degrees in Electrical Engineering from Jawaharlal Nehru Technological University (JNTU), Hyderabad, India, in 2006 and 2010 respectively, and is currently pursuing Ph.D degree at JNTU, Hyderabad, India.

He is currently working as an Asst. Professor in Department of Electrical & Electronics Engineering in Khammam Institute of Technology & Sciences. His research interests include Power systems, Power Systems protection, FACTS, power quality, Custom

Power Devices, Multilevel VSC and Distribution Generation. He is a life member of ISTE.



Dr. Pannala Krishna Murthy has secured his B. Tech in Electrical Engineering from SSGMCE- Shegoan, India, and Master's Degree from JNTU College of Engineering, Hyderabad, India. He received Doctor of Philosophy in Electrical Engineering for his work titled "Analysis & Identification of HVDC system faults using Wavelet Transforms" from JNTU, Hyderabad, India in 2010.

He is the author of the text book "Electrical Measurements & Measuring Instruments" published by I.K. International Publishing House Pvt. Ltd. New Delhi. He got more than 26 Technical Publications to his credit at International level. He has been supervising 5 Ph.D scholars of various universities. He guided more than 30 UG projects and guided 20 PG projects. At present he is working on the research problems of HVDC, Drives FACTS devices. He is a senior member of ISTE and IEEE.



Dr. G. N. Sreenivas received the B. Tech degree in electrical engineering from the JNT University College of Engineering, Hyderabad, India, in 1995, the M. Tech. degree in electrical engineering from the Osmania University, Hyderabad, India, in 2001, and the Ph.D. degrees in electrical engineering from the JNT University College of Engineering, Hyderabad, India, in 2009.

He is currently working as Professor in Department of Electrical & Electronics Engineering department & Additional Controller of Examinations in Jawaharlal Nehru Technological University Hyderabad. He Specialized in Power Systems and his research areas includes Distribution System Reliability, Power System protection, FACTS. He has 18 Years of Teaching Experience and Presented/ Published 15 Technical papers in Nation, International Conferences and Journals. He has been supervising 8 Ph.D. scholars of various universities and guided 20 UG projects and guided 30 PG projects. He was Coordinator for one National Level student's symposium and Member of system society of India (MSSI).