

# Technical and Economic Analysis of Smart Micro-Grid Renewable Energy Systems: An Applicable Case Study

M. A. Fouad, M. A. Badr, Z. S. Abd El-Rehim, Taher Halawa, Mahmoud Bayoumi, M. M. Ibrahim

**Abstract**—Renewable energy-based micro-grids are presently attracting significant consideration. The smart grid system is presently considered a reliable solution for the expected deficiency in the power required from future power systems. The purpose of this study is to determine the optimal components sizes of a micro-grid, investigating technical and economic performance with the environmental impacts. The micro grid load is divided into two small factories with electricity, both on-grid and off-grid modes are considered. The micro-grid includes photovoltaic cells, back-up diesel generator wind turbines, and battery bank. The estimated load pattern is 76 kW peak. The system is modeled and simulated by MATLAB/Simulink tool to identify the technical issues based on renewable power generation units. To evaluate system economy, two criteria are used: the net present cost and the cost of generated electricity. The most feasible system components for the selected application are obtained, based on required parameters, using HOMER simulation package. The results showed that a Wind/Photovoltaic (W/PV) on-grid system is more economical than a Wind/Photovoltaic/Diesel/Battery (W/PV/D/B) off-grid system as the cost of generated electricity (COE) is 0.266 \$/kWh and 0.316 \$/kWh, respectively. Considering the cost of carbon dioxide emissions, the off-grid will be competitive to the on-grid system as COE is found to be (0.256 \$/kWh, 0.266 \$/kWh), for on and off grid systems.

**Keywords**—Optimum energy systems, renewable energy sources, smart grid, micro-grid system, on-grid system, off-grid system, modeling and simulation, economical evaluation, net present value, cost of energy, environmental impacts.

## I. INTRODUCTION

AS we know that demand for electricity has increased extremely over the world and it will continue to increase more and more in the time to come. To moderate climate change, clean energy generation is the answer. So, more notice is brought to smart grid technology. Peng and Shi Yan [1] summarized a number of RE grid connected control methods and techniques, to overcome the randomness and unbalance of peaking capacity.

Recently, there is great interest in using micro-grids (MGs) in power systems as they are considered a flexible, intelligent, and active power network [2]. In addition, they are able to improve system reliability, efficiency, and security leading to

more promotion of renewable energy sources integration [3]. MGs can operate on-grid or use the Distributed Energy Resources (DERs) to supply the loads without the grid (i.e., standalone mode) [4], [5].

Lasseter proposed the first micro-grid architecture that was called the Clean Energy Resources Teams (CERTS) [6]. CERTS micro-grid generally assumes converter-interfaced distributed generation units based on both renewable and non-renewable power sources. A micro-grid system was also proposed by Barnes et al. [7] under the umbrella of the "Micro-grids" European project.

In the future, it is expected a spot on a micro-grid system to depend on renewable power generation units. The characteristics of a micro-grid system based on the type and size of the micro-generation units, besides the site, and the accessibility of the primary energy resources mainly renewable power sources.

Advancement in Distributed Generations (DGs) and micro-grids is accompanied by the development of various essential power conditioning interfaces and their associated control to connect multiple micro sources to the micro-grid, and attach it to the traditional network [8]. Micro-grid operation becomes very flexible and can be operated freely in the grid connected or standalone mode process. The standalone mode process possibly will be started as the main grid disconnected due to any fault.

All the last mentioned literature showed single renewable source micro-grids. The present work illustrates the simulation of a micro grid model that comprises two renewable energy sources; Photovoltaic (PV) and a wind turbine (WT) as well two modes of operation (standalone and Grid connected) are investigated.

Two studies of the micro-grid effect on reducing the cost; while improving the reliability of small scale distributed generators, using different optimization approaches were presented in [9], [10]. The proposed concepts permit high penetration of distribution generation.

Nazir et al. optimized the utilization of local RE for on-grid application. The proposed micro-grid model integrated renewable energy power plants employing a micro hydro (MHP) and PV system connected to a grid [11]. The authors used HOMER and MATLAB software. Based on the load profiles and the availability of water resources, the simulation results showed the largest capacity, MHP produced the lowest energy cost, greatest reduction of CO<sub>2</sub> emission, and largest RE fraction. The optimization model included: hybrid system,

Taher Halawa is with the Mechanical Power Engineering Dept, Faculty of Engineering, Cairo University, Egypt.

M. A. Fouad is with the Mechanical Power Engineering Dept, Faculty of Engineering, Cairo University, Egypt (e-mail: yara\_mh2003@yahoo.com).

M. A. Badr, Z. S. Abd El-Rehim, Mahmoud Bayoumi and M. M. Ibrahim are with the Mechanical Engineering Dept, National Research Centre, Cairo, Egypt.

Loss of Power Supply Probability (LPSP) and Levelized Cost of Energy (LCE) models.

As it is essential to rely on renewable energy sources to supply as much as possible energy demand, saving the limited fuel resource, reduction of greenhouse gases emissions is another advantage of using renewable energy systems [12]. In this context, a study of a micro energy grid supplying a community was presented estimating the effect of the urban micro energy grid on the reduction of energy demand and carbon emissions [13]. In this study, the authors developed a number of key performance indicators (KPIs) to act as a framework for the overall community micro energy grid design. Strategies that are site specific were adopted to meet the KPIs and minimize the capital cost of the project.

An advanced real-time energy management system was proposed by Elsieed et al. in order to optimize micro-grid performance in a real-time operation [14]. The objective of their proposed management strategy system that was based on the binary particle swarm optimization algorithm was to minimize the energy cost and pollutant emissions while maximizing the power generated from renewable resources. The authors used advanced real-time interface libraries to run the optimization code, and the simulation results were considered for three different scenarios according to the complexity of the proposed problem. To validate the simulation results, both management and control systems were experimentally tested. The results proved the effectiveness of the proposed micro-grids management system.

## II. CASE STUDY

The site under study is the National Research Centre (NRC) farm in Noubarya, almost at the mid of Cairo-Alexandria desert road. The farm is established as an experimental field for different research activities, a main part of which is agricultural. Hence, one of the applied researches there is to use crop residues to produce animal fodder. The farm soil is sand that requires the addition of water absorbing material to reduce the amount of water required for irrigation and it was recommended to add hydro-gel. Based on these applications, two small factories are established, one producing animal foddors and the other for hydro-gel production.

A MGS is suggested to supply the energy required for the two factories. The system consists of a small WT and a number of PV modules. Hence, wind and solar meteorological data were obtained based on observations of the monthly averages in the Noubarya area for the period from April 2012 to April 2015 [15]. Meteorological data of the Noubarya site; monthly average solar radiation is about 2.57 kWh/m<sup>2</sup>/day and monthly average wind speed is 5.5 m/s [16].

## III. SIMULATION OF MICRO-GRID SYSTEM

Using HOMER software, the resulted optimum MGS that supplies the above mentioned load consists of PV modules, 10 kW WT Generic type and bidirectional converter in case of grid-connected, as shown in Fig. 1 (a). In the case of operating off-grid, a diesel generator and a battery bank are integrated with the renewable generators, as shown in Fig. 1 (b).

## IV. MICRO-GRID CONTROL SWITCH UNIT

A simple control logic circuit is modeled in MATLAB/Simulink to operate the micro grid in on or off-grid mode as presented in Fig. 2. In the on-grid system, when power output from renewable is greater than the load power, excess power is exported to the grid sell block and when renewable output is less than the load power, the grid purchase block used. In the off-grid system, when power output from renewable is greater than the load power, batteries operate and excess energy is stored in it and when renewable is output less than load power, a diesel generator used to cover the shortage.

## V. MICRO-GRID ECONOMIC OPTIMIZATION RESULTS

Economic optimization of the micro grid aimed to supply the proposed load is performed using HOMER software package that explores different generators to reduce the overall system cost. The load is the electrical requirements of two small factories installed the National Research Centre (NRC) farm in Nubaryyah, Egypt. In this study, the system comprises a small wind turbine and photovoltaic, in addition to a battery bank and diesel generator in the off-grid case. NRC farm activities are mainly agricultural; hence, the crop residues are used to produce animal foddors.

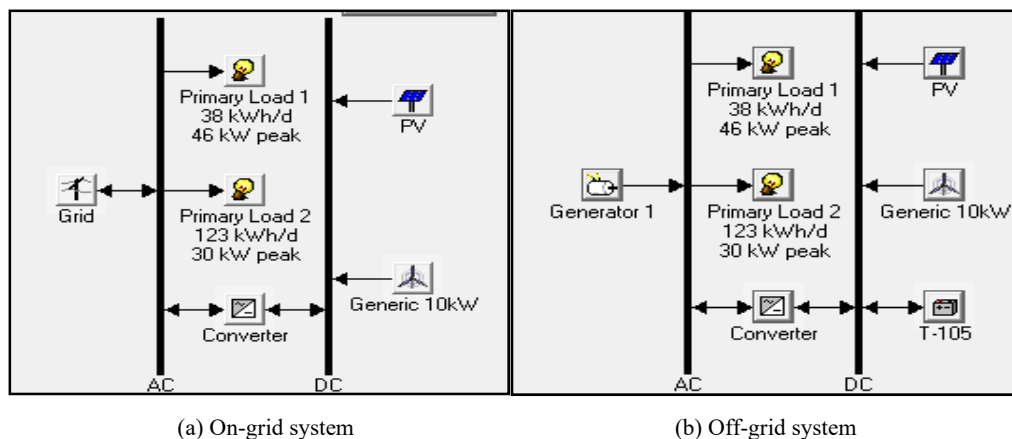

Fig. 1 WT-PV systems serving an AC load implemented in HOMER

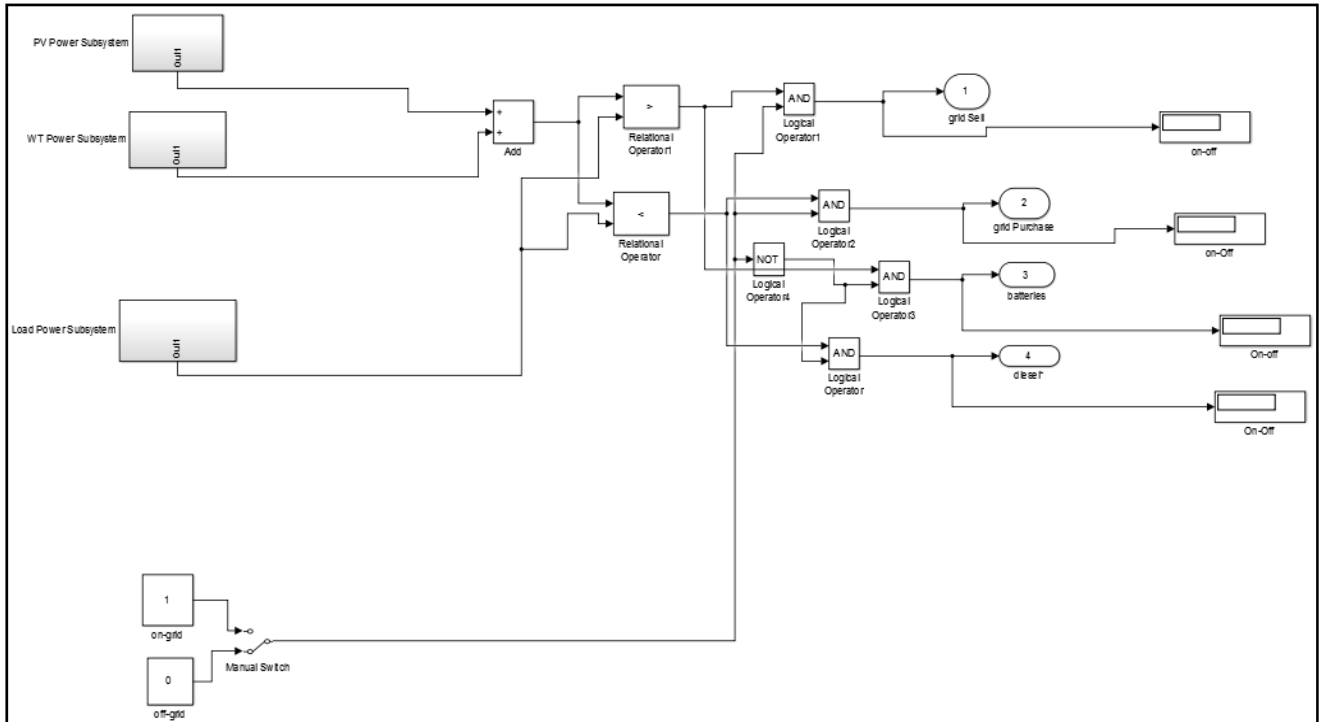

Fig. 2 Micro-Grid Control Model in MATLAB/Simulink (On/Off-grid mode)

System architecture		Sensitivity case		Annual Electric Production (kWh/yr)		Annual Electric consumption (kWh/yr)		Emissions Kg/yr	
Wind turbine	<b>3 Generic (10kW)</b>	Average solar radiation	2.57 kWh/m <sup>2</sup> /day	Wind turbine	46,644 <b>50 %</b>	AC primary load	54,127 <b>69%</b>	Carbon Dioxide	0
						Grid sales	24,618 <b>31%</b>		
PV	<b>25 kW</b>	Average wind speed	5.5 m/s	PV Array	19,227 <b>21%</b>	Total	78,745 <b>100 %</b>	Carbon Monoxide	0
				Grid purchases	27,014 <b>29%</b>	Cost summery			
Converter	<b>20 kW</b>			Total	92,885 <b>100%</b>	Levelized cost of energy	<b>0.266 \$/kWh</b>	Particulate matter	0
				Excess	8,392 <b>9%</b>	Total NPC	<b>\$184,374</b>	Sulfur dioxide	0
Grid	<b>20 kW</b>			Unmet electric Load	4,529 <b>7.7 %</b>	Renewable fraction: <b>71%</b>		Nitrogen oxides	0
Dispatch Strategy	Load following			Capacity Shortage	8,574 <b>14.6 %</b>				

Fig. 3 Optimum Cost Effective System Report Nubaryyah Site (On-Grid System)

As the farm soil is sandy, it is recommended to add hydrogel to reduce the amount of water required for irrigation. Based on these applications, two small factories are established, one for producing animal fodders and the other for hydrogel production. This section will introduce the economic and environmental performance models of solar and wind energy on this farm.

Micro-power system optimization objective is minimizing both net present cost and cost of produced energy, under the conditions of specified allowable capacity shortage and definite renewable fraction percentage. The optimization results are presented as following:

A. System Connected to Grid

Fig. 3 shows optimum cost effective system report for

Nubaryyah site. Constructing the cash flow diagram of the optimum micro-grid system, Net Present Value (NPC) is calculated for the PV life time (25 years) using a 6% discount rate.

In the previous figure, the optimum system has:

- 137 PV panels, 0.180 kW rated power each, 25 kW overall as production of 21%.
- 3 wind turbines, Generic 10, 10 kW rated power each as production of 50%.
- 20 kW grid purchases.
- Converter, 20 kW size.
- The net present cost (NPC) of the system is \$184,374 over 25 years (project life time).
- The cost of energy (COE) is 0.266 \$/kWh.
- Renewable fraction is 71%.

- Excess energy is 9%.
- Capacity shortage is 15%.

### B. System Off-Grid

Fig. 4 shows optimum cost effective system report for Nubaryyah site. Similar to the on-grid case, the cash flow diagram is constructed and the NPC is calculated.

System architecture		Sensitivity case		Annual Electric Production (kWh/yr)			Annual Electric consumption (kWh/yr)			Emissions Kg/yr	
Wind turbine	2 Generic (10kW)		5.5 m/s	Wind turbine	31,096	41 %	AC primary load	55,172	100 %	Carbon Dioxide	21,956
PV	30 kW			PV Array	23,072	30 %	Cost summery		Carbon Monoxide	54.3	
				D.G	21,754	29%					
Battery	70 Trojan T-105 6V,225Ah	Average wind speed	5.5 m/s	Total	75,922	100 %	Total net present cost	\$ 222,617	Unburned hydrocarbon	6.01	
Converter	20 kW	Average solar radiation	2.57 kWh/m <sup>2</sup> /day	Excess	15,049	19.8 %	Levelized cost of energy	0.316 \$/kWh	Particulate matter	4.09	
D.G	20 kW			Unmet electric Load	3,484	5.9 %	Operating cost	6,016 \$/yr	Sulfur dioxide	44.1	
Dispatch Strategy	Cycle Charging			Capacity Shortage	5,854	10 %	Renewable fraction:	71 %	Nitrogen oxides	484	

Fig. 4 Optimum Cost Effective System Report Nubaryyah Site (Off-Grid)

In the previous figure, the optimum system has the following configurations:

- 167 PV panels, 0.180 kW rated power each, 30 kW overall as production of 30%.
- 2 wind turbines, Generic 10, 10 kW rated power each as production of 41%.
- 20 kW Diesel Generator with 29%.
- Converter, 20 kW size.
- The net present cost (NPC) of the system is \$222,617 over 25 years (project life time).
- The cost of energy (COE) is 0.316 \$/kWh.
- Renewable fraction is 71%.
- Excess energy is 19.8%.
- Capacity shortage is 10%.

### C. CO<sub>2</sub> Emissions in Micro-Grid Planning

Reduction of pollutant emissions are anticipated using micro-grids as an alternative of conventional energy systems. The estimated off-grid system emissions are utilized to calculate the cost of CO<sub>2</sub> emissions as following:

- Avoided cost of CO<sub>2</sub> emissions is 0.0581 \$/kWh
- Cost of Energy due to avoided cost of CO<sub>2</sub> emissions = [Old cost of energy - Avoided cost of CO<sub>2</sub> emissions] = [0.316 – 0.0581] = 0.257\$/ kWh

This cost is competitive to the estimated on-grid system generated energy cost (0.266 \$/kWh) is shown in Fig. 3.

## VI. MICRO-GRID RESULTS VERIFICATION

Two types of verification were performed; the first one is verification of the simulation results modeling with MATLAB/SIMULINK and the second is verification of the HOMER software application. The details are in the following sections.

### A. Verification of Micro-Grid Components Simulation Results

#### ■ PV cell

Fig. 5 shows the manufacturer PV module characteristic (I-V & P-V) curves, while Fig. 6 exhibits these curves as resulted from simulation of the PV modeled using MATLAB/Simulink.

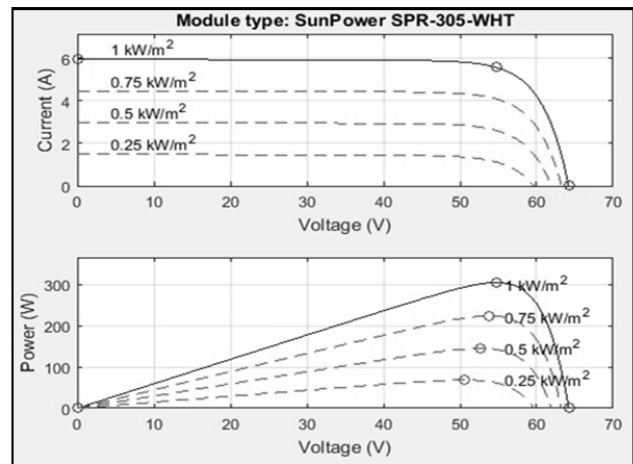
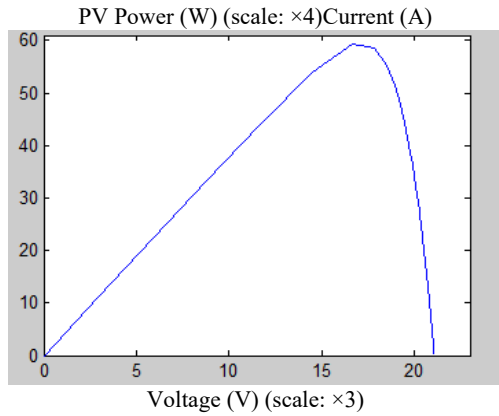

Fig. 5 PV Module Characteristics (I-V & P-V) Curves

The verification of PV cell simulation results (I-V curve) is shown in Fig. 7, while verification (P-V curve) is presented in Fig. 8.

It could be seen from Fig. 7 that the simulated current-voltage curve roughly has the same distribution with about 2% error. Also from Fig. 8, the simulated power-voltage differs from the original PV cell curve with about 9% error. So, these simulated models verified to the PV characteristics curves.



(a) P-V Curve

**MPPT**

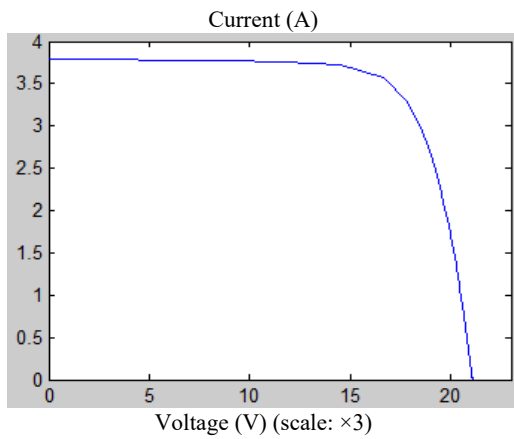

(b) I-V Curve

Fig. 6 P-V & I-V Simulated Curves of the PV Cell (Radiation 750 W/m<sup>2</sup>)

Volt (V)	I-V	I-V (Simulated)	% error
10	3.6	3.65	1.369863
20	3.6	3.62	0.552486
30	3.59	3.62	0.828729
40	3.59	3.61	0.554017
50	3.58	3.62	1.104972
60	3.3	3.4	2.941176
<b>Av. Error %</b>			<b>1.225207</b>

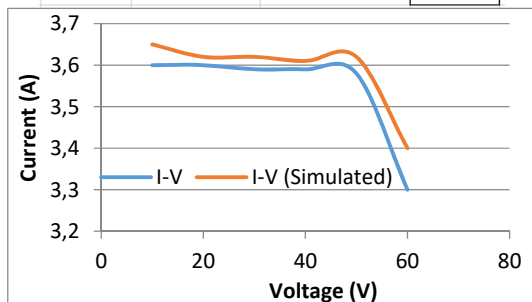

Fig. 7 Verification of PV cell (I-V curve)

Volt (V)	P-V	P-V (Simulated)	% error
10	60	75	20
20	100	120	16.66667
30	150	160	6.25
40	190	200	5
50	230	240	4.166667
60	180	190	5.263158
<b>Av. Error %</b>			<b>9.557749</b>

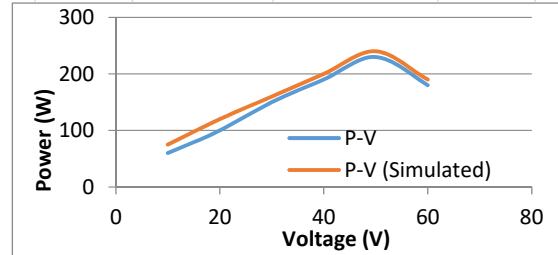
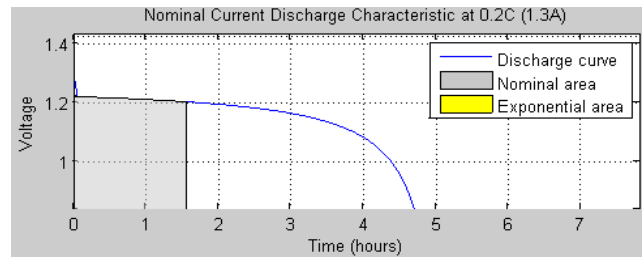

Fig. 8 Verification of PV cell (P-V curve)

▪ **Battery storage**

Battery bank characteristics are described in Fig. 9 (a). Fig. 9 (b) illustrates a comprehensive modeling of discharge battery voltage curves in MATLAB/SIMULINK. The verification of battery storage simulation results discharging (V-T curve) is shown in Fig. 10.



(a) Battery Bank Characteristics (V-T)

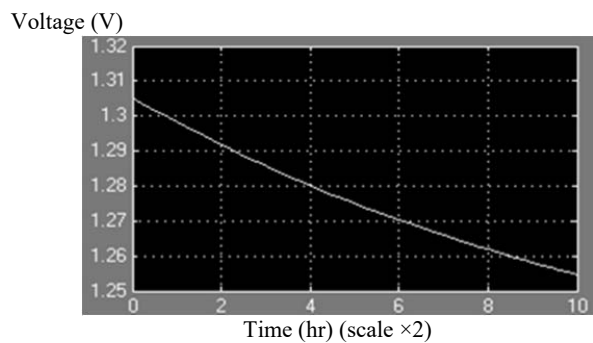

(b) Battery discharge simulated (V-T) curve

Fig. 9 Battery Characteristics Curve & Simulated Curve (V-T)

**B. Verification of HOMER Application**

A case study presented by Terefe Jima [16] was investigated to check the method of applying HOMER software. The input data listed in the pre-mentioned case study were fed to HOMER to validate the correctness of usage method. The obtained results were the same results of the case study. The optimum system configurations are:

- 12 kW PV.
- 12 wind turbines, Generic, 3 kW rated power each.



- 32 battery bank, Surrette 6CS25P, 6v-1,156 Ah each.
- Generator, 20 kW size.
- Converter, 20 kW size.

Time (hr)	V-T	V-T (Simualted)	% error
1	1.2	1.3	7.692307692
2	1.2	1.29	6.976744186
3	1.18	1.28	7.8125
4	1.1	1.28	14.0625
5	1	1.24	19.35483871
Av. Error %			11.17977812

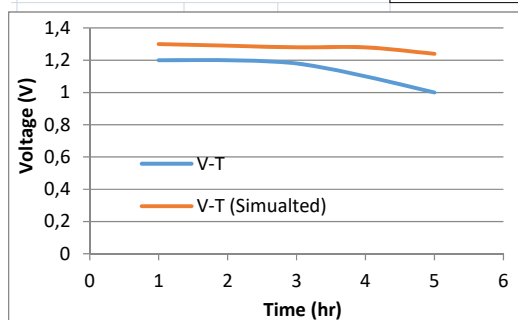

Fig. 10 Verification of Battery Discharge (V-T curve)

The calculated NPC, and COE are 739,050\$ and 0.568\$/kWh, respectively, while the results obtained by the author are listed in Table I.

TABLE I  
OPTIMIZATION RESULTS VERIFICATION OF CASE STUDY SYSTEM

PV (kW)	WT Generic	Label (kW)	Battery 6CS25P	Convtr (kW)	Initial Capital Cost (Birr)	Operating Cost (Birr/yr)	Total NPC (Birr)	COE (Birr/KWh)	Ren. Frac. (%)	Capacity Shortage	Diesel (L)	Gen (hrs)
12	12	20	32	20	3027376	802199.5	13282245	10.14024	0.85	0.00	10,463	2,701

Exchange rate to convert USD (\$) to Eth Birr is (1USD (\$) =18.37Birr).

#### REFERENCES

- [1] Li. Peng and G. Yan, "Clean Energy Grid-Connected Technology Based on Smart Grid", *Energy Procedia*, a Vol.12, pp.213 – 218, 2011.
- [2] Lidula NWA and Rajapakse AD, "Micro-grids research: a review of experimental micro-grids and test systems", *Renew Sustain Energy Rev*, a Vol.15, pp.186–202, 2014.
- [3] Huang J., "A review on distributed energy resources and micro-grid", *Renew Sustain Energy Rev*, a Vol.12, pp.2472–83, 2012.
- [4] Taha S, "Recent developments in micro-grids and example cases around the world—a review", *Renew Sustain Energy Rev*, a Vol.15, pp. 30–41, 2011.
- [5] P. Piagi and R. H. Lasseter, "Autonomous Control of Micro-grids", in *Proc. IEEE-PES06, 2006*, IEEE, 2014.
- [6] R. H. Lasseter, "Micro-grids" (distributed power generation), *IEEE Power Engineering Society Winter Meeting*, Vol.01, pp.146-149, Columbus, Ohio, Feb 2014.
- [7] M.Barnes, A. Dimeas, A. Engler, C. Fitzer, N. Hatziaargyriou, C. Jones, S. Papathanassiou, M. Vandenberg, "Micro-grid laboratory facilities", *International Conference on Future Power System*, November 2015.
- [8] M. Barnes, J. Kondoh, H. Asano, and J. Oyarzabal, "Real-World Micro-Grids- an Overview", in *IEEE Int. Conf. Systems of Systems Engineering*, pp.1-8, 2014.
- [9] A. Fathima, and K. Palanisamy, "Optimization in micro-grids with hybrid energy systems – A review", *Renewable and Sustainable Energy Reviews*, a Vol. 45, pp. 431-446, 2015.
- [10] R. Nazir, H. D. Laksono, E. P. Waldi, E. Ekaputra, and P. Coveriaa, "Renewable Energy Sources Optimization: A Micro-Grid Model Design", *Energy Procedia*, a Vol. 52, pp. 316 – 327, 2014.
- [11] Hanieh Borhanazad, Saad Mekhilef, Velappa Gounder Ganapathy, Mostafa Modiri-Delshad, and Ali Mirtaheri, " Optimization of micro-grid system using MOPSO", *Renewable Energy*, a Vol. 71 , pp. 295–306, Nov. 2014.
- [12] Wei Zhou, Chengzhi Lou, Zhongshi Li, Lin Lu, and Hongxing Yang, 'Current status of research on optimum sizing of stand-alone hybrid solar–wind power generation systems', *Applied Energy*, a Vol. 87, pp. 380–389, September 2009.
- [13] Derek Chan, Mark Cameron and Younju Yoon, "Implementation of micro energy grid: A case study of a sustainable community in China", *Energy and Buildings*, a Vol.139, pp.719–731, 2017.
- [14] Moataz Elsied, Amrane Ouakour, Hamid Gualous and Ottavio A. Lo Brutto, "Optimal economic and environment operation of micro-grid power systems", *Energy Conversion and Management*, a Vol. 122, pp.182–194, 2016.
- [15] Map of Nubaryyah, Egypt," (Online) Available: <http://Nobarya.alarmforce.com/blog/wpcontent/uploads/nubriyah.jpg>.
- [16] Jima, T., "Simulation and Optimization of Wind Turbine, Solar PV, Storage Battery and Diesel Generator Hybrid Power System for a Cluster of Micro and Small Enterprises Working on Wood and Metal Products", Addis Ababa Institute of Technology School of Graduate Studies Energy Center, 2013.

#### VII. CONCLUSIONS

- ❖ Simulation of an RE micro-grid system emphasized that the increase of RE fraction decreases the NPV and COE. Results obtained a number of feasible alternatives of RE micro grids for several levels of renewable penetration. The optimization results showed that:
  - NPC & COE of an on-grid system are \$184,374, 0.266\$/kWh, respectively.
  - NPC & COE of an off-grid system are \$226,617, 0.316\$/kWh, respectively.
  - On-grid configuration system is the best solution for this case study.
  - Calculating the cost of avoided CO<sub>2</sub> emissions, the modified cost of energy (COE) in the case of the off-grid is found to be 0.265 \$/kWh, which is less than its value in the case of the on-grid system.
- ❖ A micro-grid system modeling that is based on renewable power generation units is presented in this paper in two operational modes; standalone and grid connected using MATLAB/Simulink software package.
- ❖ Verification of MG results was performed on two types; first on simulated results using MATLAB/Simulink and the second on the HOMER application case study.